

MANISCOPIC

MT 1440 MT 1440 EP PRIVILEGE





- Maximum lifting height : 13.53 m
- Capacity : 4000 kg
- Maximum forward reach : 9.38 m
- Torque convertor
- Hydraulic stabilizers
- Frame levelling : $\pm 9^\circ$

 **MANITOU**

MT 1440 MT 1440 EP

PRIVILEGE

 **Lifting capacity**4000 kg
at 500 mm from forks heels.
Tipping load at maximum reach :
with stabilizers1950 kg
Tear out force with bucket
to ISO 83138000 daN

 **Lifting height**13.53 m
Times : unladen / loaded (in s)
Lifting (standard)16/16.2
Lifting (EP)12.5/12.7
Lowering13.5/13.2
Extension boom19.5/20.1
Retraction boom14.5/15
Crowd4.3
Dump4

 **Tyres**400/80-24

 **Forks (mm)**
Length1200
Width x thickness125 X 50
Maximum distance between forks1040
Carriage rotation126°

 **Multidisc brakes - hydraulically assisted on both axles**

 **PERKINS Engine**
Type1104C.44 T
Capacity4 cylindres - 4400 cm³
Power :
(ISO/TR 14396) ...101 HP/74.5 kW at 2200 rpm
Maximum torque413 Nm at 1350 rpm
Direct Injection
Water Cooling

 **Transmission**Torque convertor
Electro-hydraulic reversing shift
4 speeds forward and reverse
Maximum travel speed (km/h)25

 **Hydraulics**
Pumpgear type
pressure/capacity270 bars/170 l/mn

 **Capacities**
Cooling system20 l.
Engine oil10.9 l.
Hydraulic oil135 l.
Transmission oil23 l.
Fuel tank140 l.

 **Weight unladen**10800 kg
Overall width2.38 m
Overall height2.45 m
Turning radius (outside wheels)3.98 m
Overall Length6.13 m
Ground clearance0.38 m
Drawbar pull10200 daN

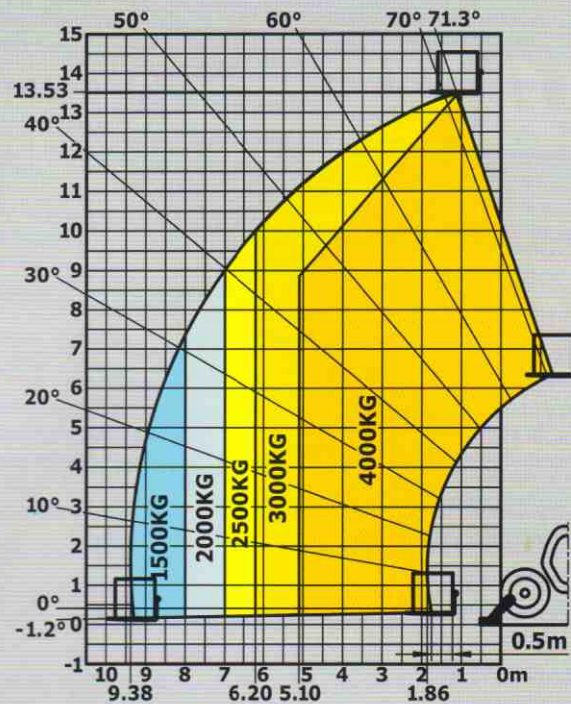

Under
EN 1459
annexe B

A	1200
B	3070
C	1905
C1	1790
D	6135
D1	6020
D2	4829
E	7335
F	1960
F1	1960
G	384
G1	367
G2	380
G3	355
H	9
H1	9
I	1160
J	892
K	1040
L	50
N	1855
O	125
P2	34
P3	33
R	3779
S	8651
T	4183
U1	2452
U2	2640
V	5468
V1	1285
V2	3986
W	2374
W1	3793
W2	1134
W3	2422
Y	12
Z	114

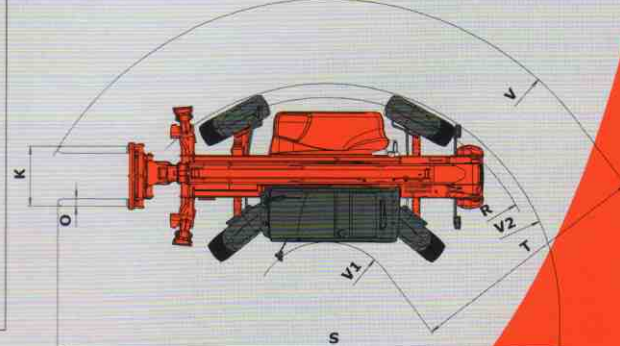
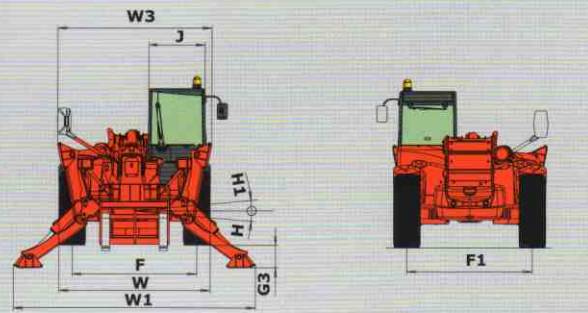
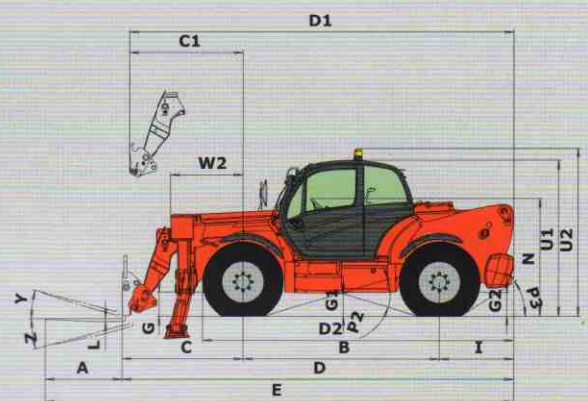

The specifications contained herein shall not bind the manufacturer and are subject to change without notice. This equipment described in this leaflet may be standard, optional, or unavailable, depending on the versions. For more details, contact your MANITOU dealer.

